

RWHA Series – Aluminium floor jacks Light models for flat, sports vehicles

- ▶ Very flat, designed specifically with vehicles with lowered suspension
- ▶ Valve control via interior rods and rotary button on pump lever
- ▶ Slow, safe lowering under load
- ▶ Convenient and easy lifting thanks to hydraulics and long lever
- ▶ Two practical aluminium handles at sides

RWHA 1500

- ▶ Lightweight, robust aluminium design
- ▶ With stable load roller
- ▶ Rubber mat protects pad and vehicle

RWHA 2500

- ▶ Robust aluminium and steel construction
- ▶ QUICK LIFT function of RWHA 2500: reaches max. height with just 7 pump movements



With double-action pump



RWHA 1500

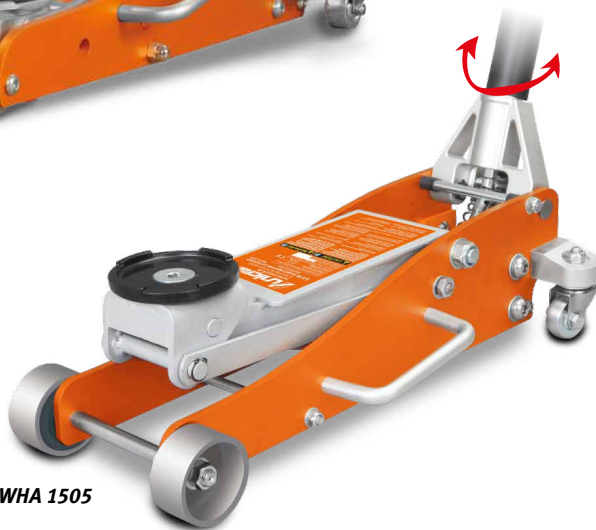

RWHA 1505



RWHA 2500

▶ Turn to lower



RWHA 1500



▶ For lowered chassis



▶ Rubber mat on pad and pump lever sleeve protect the vehicle chassis



Long lever with premium handle for lowering

Model	RWHA 1500	RWHA 1505	RWHA 2500
Art. no.	6201106	6201110	6201109
Technical Data			
Load-bearing capacity	1.5 t	1.5 t	2.5 t
Min. clearance	85 mm	85 mm	100 mm
Final height max.	445 mm	375 mm	465 mm
Length	660 mm	576 mm	650 mm
Width	294 mm	250 mm	292 mm
Height	170 mm	154 mm	170 mm
Weight	19.5 kg	18.5 kg	26.4 kg